

Flite-Veyor®

**Horizontal Flat Bottom Drag Conveyors
17 Series • 26 Series • 33 Series**

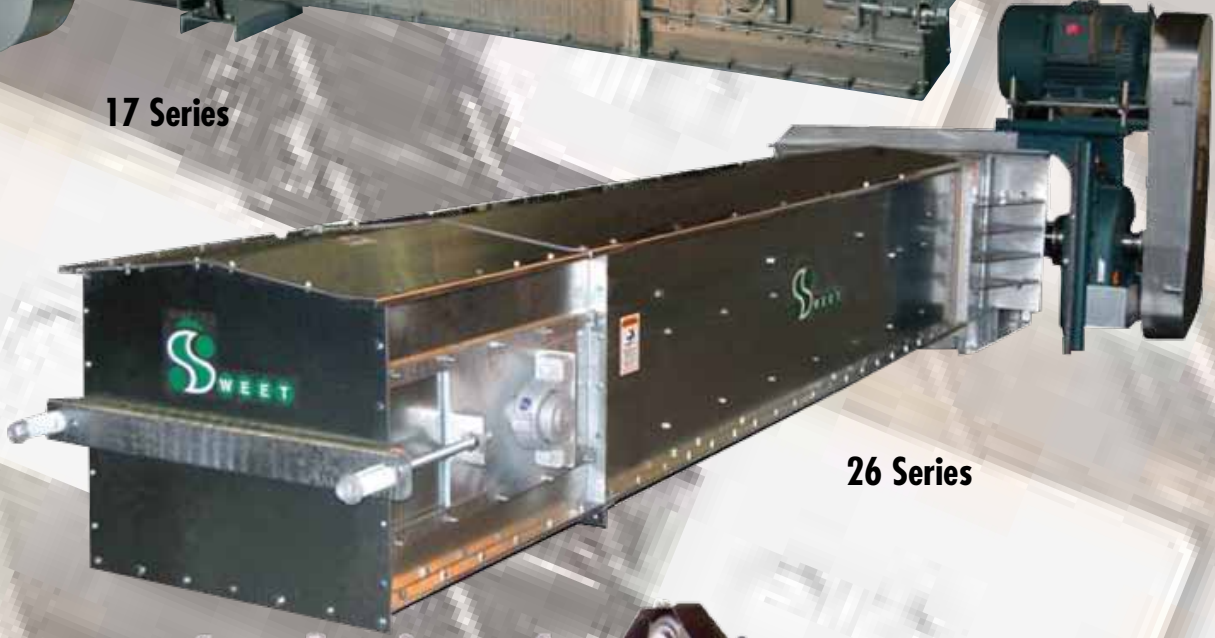

17 Series



26 Series



33 Series



SWEET®

OUR MISSION: To provide innovative quality solutions that create an extraordinary customer experience.

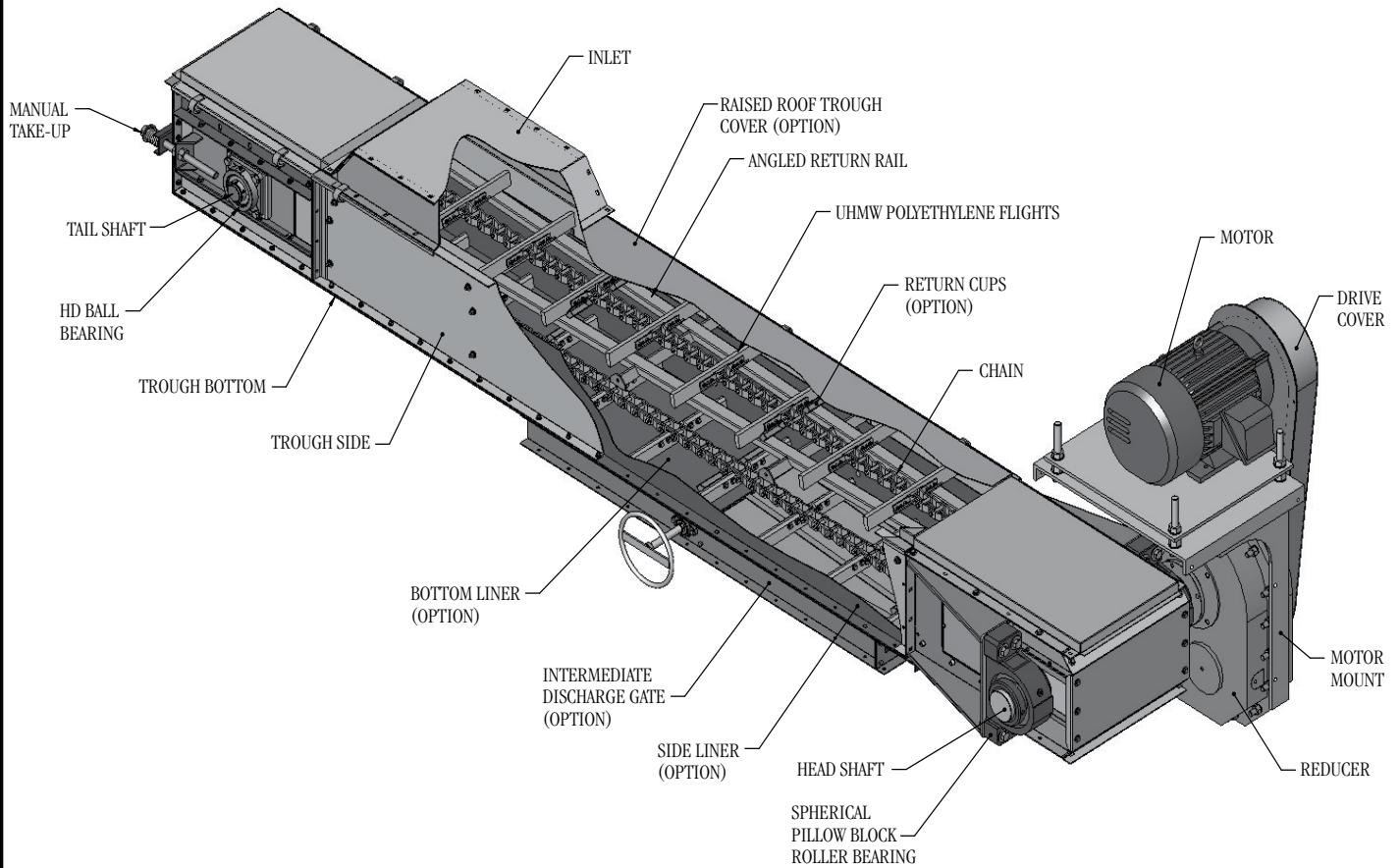

TAIL

- 3/16" galvanized steel
- Heavy duty 1/4" take-up plate weldments
- Heavy duty screw take-ups with shock spring

TROUGH

- Preassembled trough sections to reduce installation time
- No metal-to-metal contact of chain to trough
- Jig welded 3/16" connecting flanges for alignment
- Angled rail returns
- Removable bottom for easy replacement of liners and servicing
- Many cover types available (hip roof or flat)
- 10 ga. galvanized sides and bottom standard

HEAD

- 3/16" and 1/4" hot-dipped galvanized steel to protect against corrosion
- Removable head shell for ease of access to sprocket, bearings and shaft
- Heavy duty 1/4" – 1/2" bearing mounting angles
- 17 series double spherical PB roller bearings
- Split housing, double spherical PB roller bearings, adapter mounted standard on 26 and 33 series

CHAIN

- Optimum chain support for even wear of flights
- 1/2" and 3/4" thick UHMW replaceable flights with steel angle reinforcing chain attachments
- Up to 20,250 lbs. working in load (140,000 lbs. ultimate strength)
- Steel pintle chain on smaller capacity units
- Welded steel chain on larger capacity units

OPTIONS

- Extra standard inlets
- Bypass inlets
- Dump hoppers
- Intermediate discharge gates
- Chain slack switch
- Hinged pressure relief door
- 10 gauge (ga.), 3/16" and 1/4" AR 200 liner
- 3/16" and 1/4" AR 400 liner
- 3/16" galvanized sides and bottoms
- Split sprocket and hardened teeth
- Overlapping V-pattern return rails
- Roller returns

GAUGES & SPECIFICATIONS

HEAD	3/16 ga.
TAIL	10 ga.
TROUGH	10 ga.
COVER	14 ga.
CHAINS	D88K, D88C, W124, W132, WHX2855, D308C

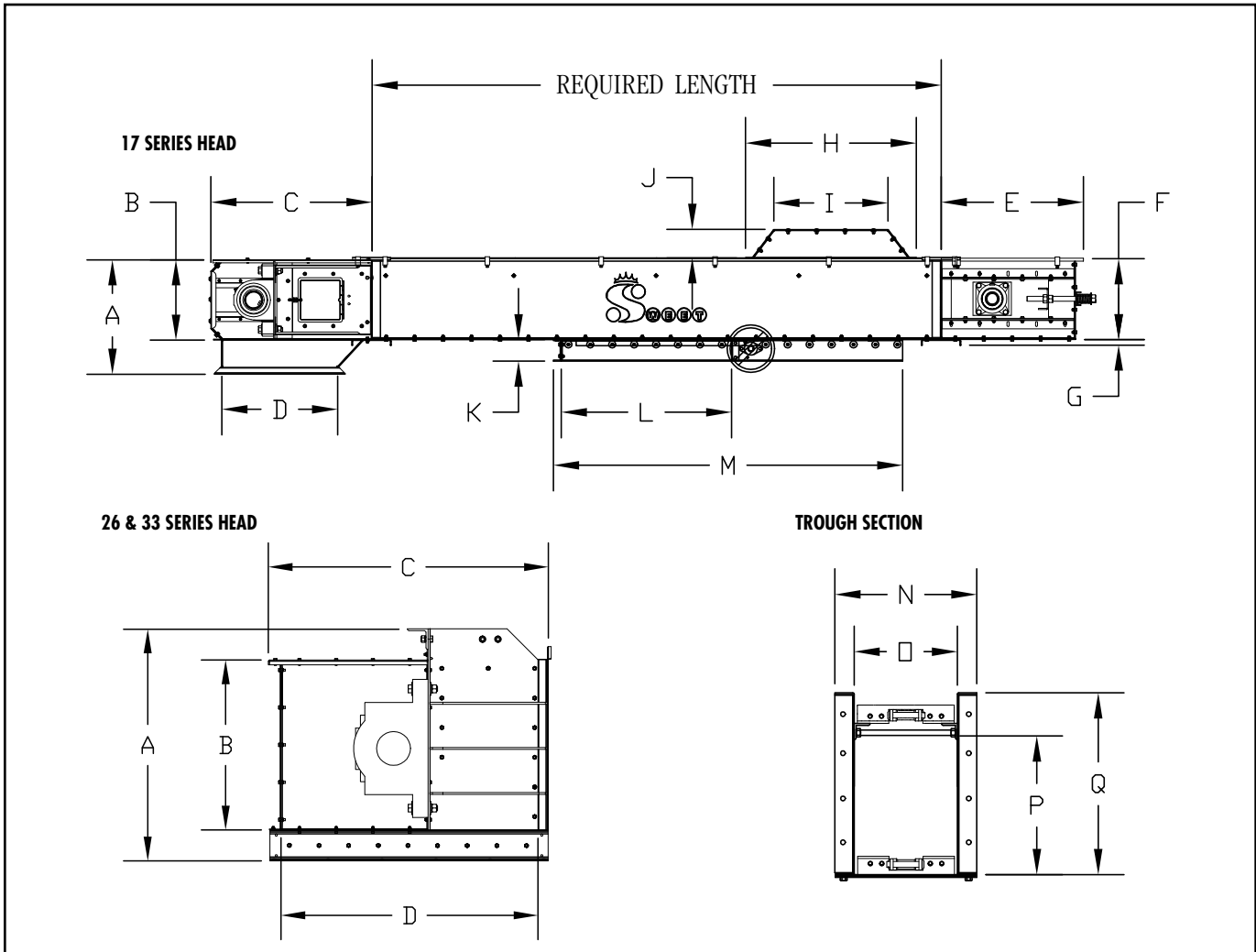

DIMENSIONS

		17 SERIES					26 SERIES			33 SERIES	
		1017	1417	1817	2017	2417	1826	2426	3026	3033	3633
HEAD	A	24"	24"	24"	24"	24"	36"	36"	38"	39"	39"
	B	17"	17"	17"	17"	17"	26"	26"	26"	33"	33"
	C	34"	34"	34"	34"	34"	40.875"	40.875"	46.3125"	54.5"	54.5"
	D	24"	24"	24"	24"	24"	35.75"	35.75"	42.5"	49.25"	49.25"
TAIL	E	30"	30"	30"	30"	30"	38"	38"	38"	60"	60"
	F	17"	17"	17"	17"	17"	26"	26"	26"	33"	33"
	G	1.125"	1.125"	1.125"	1.125"	1.125"	2"	2"	2"	2.25"	2.25"
TROUGH	H	36"	36"	36"	36"	36"	45"	45"	45"	62.75"	62.75"
	I	24"	24"	24"	24"	24"	29"	29"	29"	42.125"	42.125"
	J	6"	6"	6"	6"	6"	6"	6"	6"	8.375"	8.375"
	K	4.5"	4.5"	4.5"	4.5"	4.5"	4.5"	4.5"	4.5"	-	-
	L	36"	36"	36"	36"	36"	36"	36"	36"	-	-
	M	73.75"	73.75"	73.75"	73.75"	73.75"	74"	74"	74"	-	-
	N	13.5"	17.5"	21.5"	23.5"	27.5"	22.25"	28.25"	34.25"	34.375"	40.375"
	O	10"	14"	18"	20"	24"	18"	24"	30"	30"	36"
	P	13"	13"	13"	13"	13"	20"	20"	20"	25.25"	25.25"
	Q	17"	17"	17"	17"	17"	26"	26"	26"	33"	33"

Note: Dimensions (in inches) are for reference only and may be subject to change.

Horizontal Flat Bottom Drag Conveyors

OPTIONS

EXTRA STANDARD INLET

Standard angle flange inlets are recommended for use on applications where material flow is controlled before entering the conveyor.

BYPASS INLET

Bypass inlet funnels grain directly into the lower portion of the trough. This method of feeding provides automatic flow control into the conveyor, preventing pressure buildup on the chain. The bypass inlet is recommended where flow control is not provided before entering the conveyor.

DUMP HOPPER

Dump hoppers replace a section of the trough for use in pit applications. The hopper diverts material around the return chain and provides an even flow into the lower portion of the Flite-Veyor®. This prevents pressure buildup on the chain and reduces horsepower requirements. The dump hopper is available in different lengths.

INTERMEDIATE DISCHARGE

Intermediate discharges have a 36" (91.44 cm) opening. Steel cross members support the chain over the opening while allowing 100% of the material to discharge.

The intermediate discharge has a side opening or inline slide gate with manual, rack and pinion, electric, or pneumatic controls available. An optional discharge transition tapers the 36" (91.44 cm) long opening down to an opening that is 18" (45.72 cm) long.

OPTIONAL TROUGH LINERS

Optional choices of abrasive resistant (AR) side and/or bottom lined trough sections are available.

Liner Sides

- 10 ga.
- 3/16" AR
- 1/4" AR

Liner Bottoms

- 10 ga.
- 3/16" AR
- 1/4" AR

BYPASS INLET

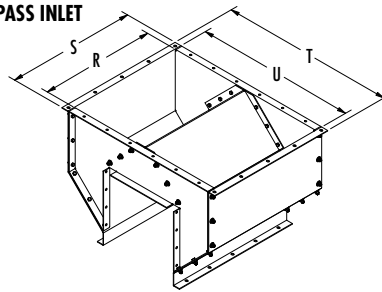

DUMP HOPPER ASSEMBLY

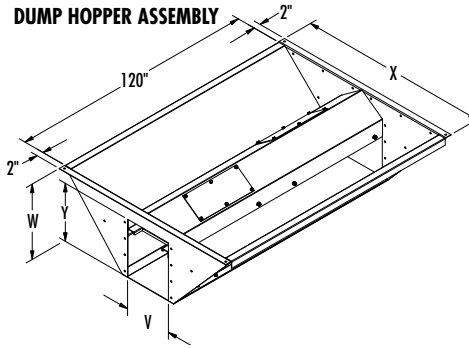

DIMENSIONS

Model Number	Bypass Inlet				Dump Hopper			
	R	S	T	U	V	W	X	Y
1017	18"	21.5"	22"	25.5"	10"	22"	48"	17"
1417	18"	21.5"	26"	29.5"	14"	22"	52"	17"
1817	18"	21.5"	30"	33.5"	18"	22"	56"	17"
2017	18"	21.5"	32"	35.5"	20"	27"	68"	17"
2417	18"	21.5"	42"	45.5"	24"	26"	75"	17"
1826	35.5"	40"	38.5"	42.5"	18"	35.5"	85"	26"
2426	35.5"	40"	44.5"	48.5"	24"	35.5"	90"	26"
3026	35.5"	40"	50.5"	54.5"	30"	39"	103.5"	26"
3033	50"	54"	57.5"	61.5"	30"	48"	122"	33"
3633	50"	54"	63.5"	67.5"	36"	51"	134"	33"

Note: Dimensions (to the nearest 1/2 inch) are for reference only and may be subject to change.

INTERMEDIATE DISCHARGE GATE WITH TRANSITION



INTERMEDIATE DISCHARGE GATE SIDE OPERATION WITH TRANSITION

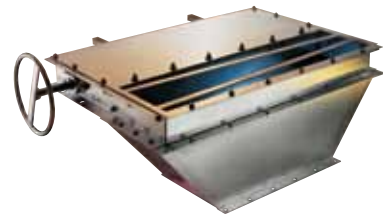

CHAIN SLACK SWITCH



HINGED PRESSURE RELIEF DOOR





THE *Flite-Veyor*[®] DIFFERENCE

The Flite-Veyor[®] line of horizontal flat bottom drag conveyors from Sweet has been designed for ease of installation and with premium parts and workmanship for a longer operating life. The Flite-Veyor[®] line offers a wide range of models and options within 3 series – 17 series, 26 series and 33 series – with capacities ranging up to 50,000 bph/1,355 mtph. Our range and flexibility can help meet the unique demands of your application – size, speed, throughput and overall processing capacity. The Flite-Veyor[®] line features:

- Complete galvanized construction, including hot-dip galvanizing of all structural steel.
- Large field cut inlets for ease of connection and location for loading.
- Chain with UHMW polyethylene replaceable flights which create positive flow and minimize friction.
- Head assembly pillow block bearing bases mounted in the optimum position, perpendicular to the load.
- Design specifications listed with a standard Class II drive package.
- Zinc plated tie rods, nickel plated bushings and hot-dip galvanized motor mounts standard with all drive packages.

HORIZONTAL *Flite-Veyor*[®] CAPACITY CHART

Capacity	17 SERIES					26 SERIES			33 SERIES	
	1017	1417	1817	2017	2417	1826	2426	3026	3033	3633
Bushels/Hour (Metric Tons/ Hour)	10(w)x17(h) FPM / MPS	14(w)x17(h) FPM / MPS	18(w)x17(h) FPM / MPS	20(w)x17(h) FPM / MPS	24(w)x17(h) FPM / MPS	18(w)x26(h) FPM / MPS	24(w)x26(h) FPM / MPS	30(w)x26(h) FPM / MPS	30(w)x33(h) FPM / MPS	36(w)x33(h) FPM / MPS
3,000 (81)	78 / .40									
4,000 (108)	104 / .53									
5,000 (136)	130 / .66									
6,000 (163)	156 / .79	111 / .56								
7,000 (190)	182 / .92	128 / .65	100 / .51							
8,000 (216)		147 / .75	114 / .58	104 / .53						
9,000 (244)		166 / .84	128 / .65	116 / .60						
10,000 (271)		185 / .94	143 / .73	129 / .66	104 / .53	93 / .47				
11,000 (298)		200 / 1.02	157 / .80	142 / .72	118 / .60	105 / .53				
12,000 (325)			171 / .87	154 / .78	125 / .63	112 / .57				
13,000 (352)			186 / .94	167 / .85	139 / .71	124 / .63	94 / .46			
14,000 (379)			200 / 1.02	180 / .91	146 / .74	133 / .68	101 / .51			
15,000 (407)				194 / .99	156 / .79	140 / .71	105 / .53	84 / .43		
16,000 (434)					167 / .85	152 / .77	112 / .57	89 / .45		
20,000 (542)						186 / .94	140 / .71	112 / .57		
25,000 (678)							175 / .89	140 / .71	107 / .54	
28,000 (759)							196 / 1.00	156 / .79	119 / .60	106 / .54
30,000 (813)								168 / .85	128 / .65	114 / .58
35,000 (949)								195 / .99	148 / .75	133 / .68
40,000 (1084)									169 / .86	150 / .76
45,000 (1220)									190 / .97	168 / .85
50,000 (1355)										188 / .96

FPM= Feet per minute MPS= Meters per second

Flite-Veyor® Horizontal Flat Bottom Drag Conveyors



OTHER CONVEYORS AVAILABLE FROM SWEET:

Flite-Veyor® Incline Flat Bottom Drag Conveyors, Flite-Veyor® Round Bottom Drag Conveyors, Formed Channel Belt Conveyors and Quick-Key® Spool Belt Conveyors.



Telephone: 937-325-1511
 Fax: 937-322-1963
 Toll Free: 1-800-334-7254
 Website: www.sweetmfg.com
 E-mail: sales@sweetmfg.com



MEMBER OF

